

IMPORTANT:

Due to the wide variety of media you may need to adjust the heat setting of your laminator to get the best transfer. If the laminate is not fully transferring to the disc, the heat must be increased. However, if the heat is set too high, the printed image on the disc may be distorted. Excessive heat may even cause the label side to peel off of the disc. Because of this you should use the least amount of heat necessary to transfer the laminate film to the surface of your disc.

4 Adjusting the Center Hub

1. If the laminate is not adhering to the hub in the same manner as the rest of the disc, you may wish to avoid laminating the center hub. To do this, lift the Tray Disc Hub Spacer from the center of the Disc Tray and rotate it slightly clockwise. Place it back into the center of the Disc Tray making certain it seats properly in the tray.
2. Repeat the test with another disc. When you are satisfied with the setting, you may want to make a note of them for future reference. You are now ready to laminate your discs.

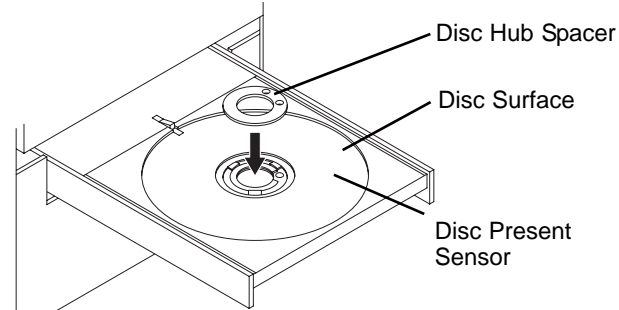

With the Disc Tray Hub in this position, laminate will be transferred to the hub of the disc.

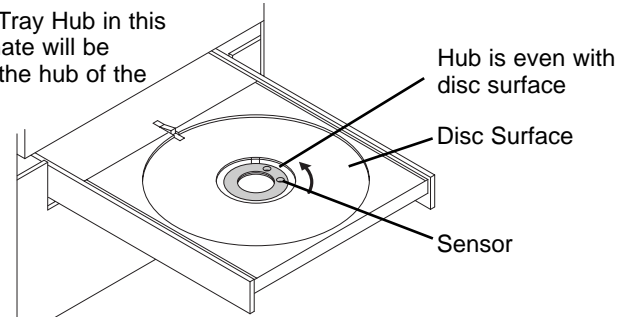

With the Disc Tray Hub in this position, laminate will NOT be transferred to the hub of the disc.

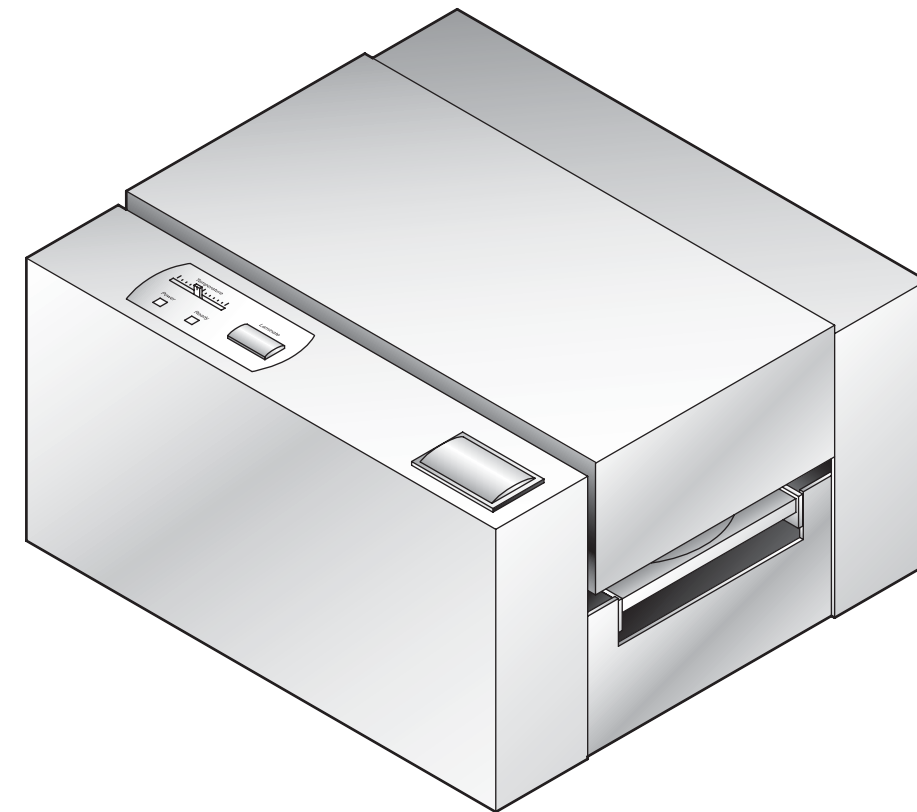
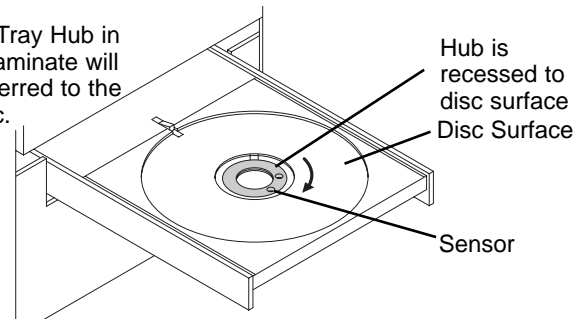

Quick Start

PRIMERA

© 2005 All rights reserved.

P/N 510893-021505

Congratulations on the purchase of your new Accent™ Disc Laminator (referred to in this document as the "Laminator"). This Quick Start Guide will describe the step-by-step process of setting up your Laminator. This includes information on how to load the supplies (Lamination Film and disc media) necessary to start laminating discs. For more complete information regarding all aspects of your Laminator's operation, please refer to the User's Manual.

1 Applying the Power

1. Locate the power cord supplied with your Laminator.
2. Place one end of the power cord into the power port located on the rear panel of the Laminator.
3. Plug the power cord into an available outlet. Avoid plugging your Laminator into a battery backup or uninterruptible power supply.

About Lamination Film and Optical Media

Lamination Film for your Optical Disc Laminator is available in both a clear and holographic finish. The Holographic Overlaminant is used as a security feature making your discs easily identifiable as authentic. Holographic Overlaminant is also available with your own design when purchased in quantity. Please contact your dealer for details. Most inkjet printable discs will work well with some adjusting for heat. Because it is impossible to test all types of media, it is highly recommended you purchase a small amount for testing before committing to a large, bulk purchase of media.

If you are having trouble with lamination quality, consider purchasing Accent Certified Media Kits. Kits contain CDs or DVDs that are specifically tested and certified for use with the Accent. These discs are the best possible combination of burnable surface, printable surface and lamination surface. For more information, visit our web store at www.primera.com.

2 Installing Lamination Ribbons

1. Press the Access Cover Button to open the Access Cover.

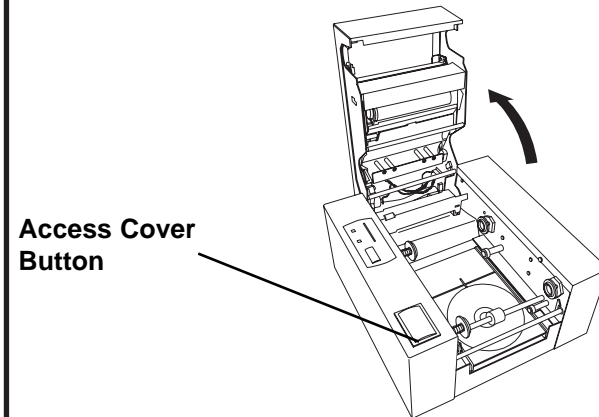

2. Remove the Overlaminant Film and Take-Up Core from its packaging. The film comes pre-rolled on a core with a separate Take-Up Core included in the package.

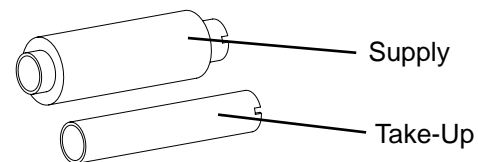

3. Place the Take-Up Core in the front of the Laminator between the black plastic Ribbon Drive Hubs as shown. The left-side Hub is spring loaded. The right-side Hub has tabs that will engage and lock in place with the notches in the right-side of the Take-Up Core.

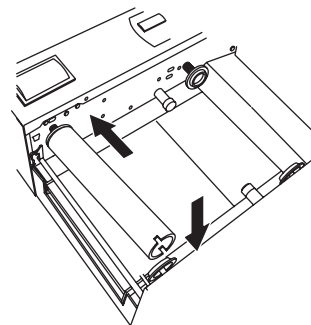

2 Installing Lamination Ribbons (continued)

4. Insert the Overlaminant Film in the rear set of hubs inside the Laminator as shown, keeping in mind that the Laminant will feed from over the top of the roll and the notches in the core will need to face the right-side of the laminator to lock in place with the ribbon drive hub.

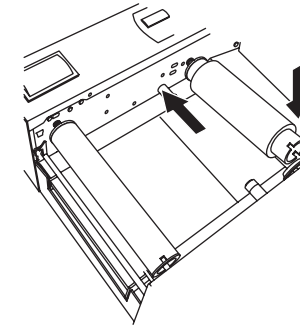

5. The white portion of the leading edge of Overlaminant film has an adhesive coating. Pull it forward as shown, attaching it to the front Take-Up core. Turn the Take-Up Core towards the front of the laminator over the top to ensure the Overlaminant film is securely attached. When properly loaded the film will feed from over the top of the supply roll in back and will travel over the top of the Take-Up Core in front.

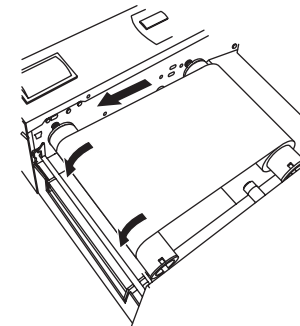

3 Laminating Discs in Stand Alone Operation

Now that you have successfully loaded the Lamination Film, you are ready to laminate your discs.

1. Turn the Laminator Power Switch to the ON position. Press the Laminate button. The Disc Tray should automatically eject from the Laminator and the Thermal Roller

3 Laminating Discs in Stand Alone Operation (continued)

will start heating up to operating temperature. Move the Temperature Control Lever to the desired setting. (The middle setting is recommended initially.) The Ready LED should flash intermittently while the roller is heating. The process should take about 8-15 minutes.

NOTE: The Laminator will automatically go into 'cool down' mode after 30 minutes of inactivity.

2. Once the READY LED is on and steady, the Laminator is at heat and ready to laminate your discs. You may need to make adjustments to the Laminator heat settings to ensure high quality output. Start with a test lamination to see if any adjustment will need to be made. This is done as follows:
 - a. Place a disc on the Disc Tray.
 - b. Press the Laminate Button.
 - c. The disc will be drawn into the Laminator, laminated and the tray will be ejected.
 - d. Examine the disc. If the lamination looks spotty, more heat is required. Increase the intensity. If the lamination shows scratch-like marks, the film is getting too hot and wrinkling. Reduce the heat setting.



Wrinkle in film caused by excessive heat

Uneven coverage due to inadequate heat