

SignatureEVO

SLIDE PRINTER

User's Manual

031023

© 2023 All rights reserved.

For the most recent version of this manual please visit
<http://www.primera.com/slideprinterdownloads>

Table of Contents

Section 1: Getting Started	4
1A. Choosing a Good Location.....	4
1B. Unpacking and Inspection	5
1C. Identifying the Parts	6
1D. Slide Specifications.....	8
1E. Connect Power	9
1F. Load a Ribbon	10
1G. Load a Slide Cartridge	13
Section 2: Printing Slides	17
2A. Printing from other Programs	17
2B. Printer Driver Settings	17
Section 3: Maintenance and Troubleshooting	19
3A. Control Panel Status Messages, Indicator Lights and Error Codes	19
3B. Cleaning the Print Head.....	21
3C. Replacing the Print Head	23
3D. Troubleshooting Print Quality.....	26
3E Changing the Spring Force (Printing Pressure).....	27
3F. Repairing/Preventing Ribbon Breaks.....	28
3G. Retrieving a Broken Slide	29
3H. Cartridge or Ribbon Recognition Problems	30
3I. Adjusting the Slide Separating System	31
3J. Technical Support.....	32
Section 4. Technical Specifications.....	33
Section 5 Compliance	34

Notices: The information in this document is subject to change without notice. NO WARRANTY OF ANY KIND IS MADE WITH REGARD TO THIS MATERIAL, INCLUDING, BUT NOT LIMITED TO, THE IMPLIED WARRANTIES OF MERCHANTABILITY AND FITNESS FOR A PARTICULAR PURPOSE. No liability is assumed for errors contained herein or for incidental or consequential damages in connection with the furnishing, performance, or use of this material. This document contains proprietary information that is protected by copyright. All rights are reserved. No part of this document may be photocopied, reproduced, or translated into another language without prior written consent.

Trademark Acknowledgments: Windows is a registered trademark of Microsoft Corporation. All other trademarks are the property of their respective owners.

Printing History

Edition 1.0, 030123, 511311 Copyright 2023, All rights reserved.

FCC Compliance Statement: This device complies with part 15 of the FCC rules. Operation is subject to the following two conditions: (1) this device may not cause harmful interference, and (2) this device must accept any interference received, including interference that may cause undesired operation.

For Users in the United States: This product is intended to be supplied by a UL listed Direct Plug-In

Power Supply marked "Class 2" or a UL listed ITE Power Supply marked "LPS" with output rated

12VDC, 5A or higher. This equipment has been tested and found to comply with the limits for a Class B digital device, pursuant to Part 15 of the FCC Rules. In a domestic environment this product may cause radio interference, in which case the user may be required to take adequate measures. This equipment generates, uses, and can radiate radio frequency energy and, if not installed and used in accordance with the instructions, may cause harmful interference to radio communications. However, there is no guarantee that interference will not occur in a particular installation. If this equipment does cause harmful interference to radio or television reception, which can be determined by turning the equipment off and on, the user is encouraged to try to correct the interference by one or more of the following measures:

- Re-orient or relocate the receiving antenna.
- Increase the separation between the equipment and receiver.
- Connect the equipment into an outlet on a circuit different from that to which the receiver is connected.
- Consult the dealer or an experienced radio/TV technician for help.

Use of shielded cables is required to comply with the Class B limits of Part 15 of the FCC Rules. You are cautioned that any changes or modifications not expressly approved in this manual could void your authority to operate and/or obtain warranty service for this equipment.

For Users in Canada: This digital apparatus does not exceed the Class B limits for radio noise for digital apparatus set out on the Radio Interference Regulations of the Canadian Department of Communications. Le présent appareil numérique n'émet pas de bruits radioélectriques dépassant les limites applicables aux appareils numériques de la class B prescrites dans le Règlement sur le brouillage radioélectrique édicté par le ministère des Communications du Canada.

Product Disposal

Do not dispose of the Printer or supplies in the same manner as normal household waste. Consult your local authorities for disposal and recycling options.

WARNING

THE PRINT AREA CONTAINS HAZARDOUS MOVING PARTS. KEEP FINGERS AND OTHER BODY PARTS AWAY.

CAUTION!

TO PREVENT FIRE OR SHOCK HAZARD, DO NOT EXPOSE THE UNIT TO RAIN OR MOISTURE. TO REDUCE THE RISK OF ELECTRIC SHOCK, DO NOT REMOVE EXTERIOR PANELS. NO USER-SERVICEABLE PARTS INSIDE. REFER SERVICING TO QUALIFIED SERVICE PERSONNEL. OPERATE THE UNIT WITH ONLY THE PROPER ELECTRICAL SPECIFICATIONS AS LABELED ON THE PRINTER AND AC ADAPTER.

Section 1: Getting Started

THANK YOU...

...for purchasing a Signature EVO Slide Printer. The Signature EVO Slide Printer can significantly increase the efficiency of your lab while helping to reduce the risk of misidentification of specimens. It prints directly onto slides, eliminating handwriting or expensive, difficult to apply xylene-resistant labels. With impressive 300 dpi print resolution, you can print text, graphics and logos along with high-resolution linear and 2D bar codes on every slide you process.

To begin using your Signature EVO, please read this manual carefully. This Operator's Manual is a guide to the Signature EVO Slide Printer only. There are other accessories and software that work with the Signature EVO Slide Printers. Those items are purchased separately and include their own user's manual.

NOTE ON TERMS AND CONVENTIONS

From this point forward, the following terms and conventions will apply:

The Signature EVO Slide Printer will be referred to simply as the Printer.

1A. Choosing a Good Location

- Place the Printer in a location with adequate air circulation to prevent internal heat build-up. You will need at least 18" (46 cm) of overhead space to allow the top cover to open freely.
- Do not place the Printer near heat sources such as radiators or air ducts, or in a place subject to direct sunlight, excessive dust, mechanical vibration or shock.

1B. Unpacking and Inspection

While unpacking your Printer, inspect the carton to ensure that no damage has occurred during shipping. Make sure that all supplied accessories are included with your unit.

The following items should be included:

1. Signature EVO Slide Printer
2. Power cord
3. Power converter
4. USB cable
5. 100 pack of slides
6. Blue slide cartridge
7. Color and Black ribbon
8. Print head cleaning pen
9. Polishing Paper

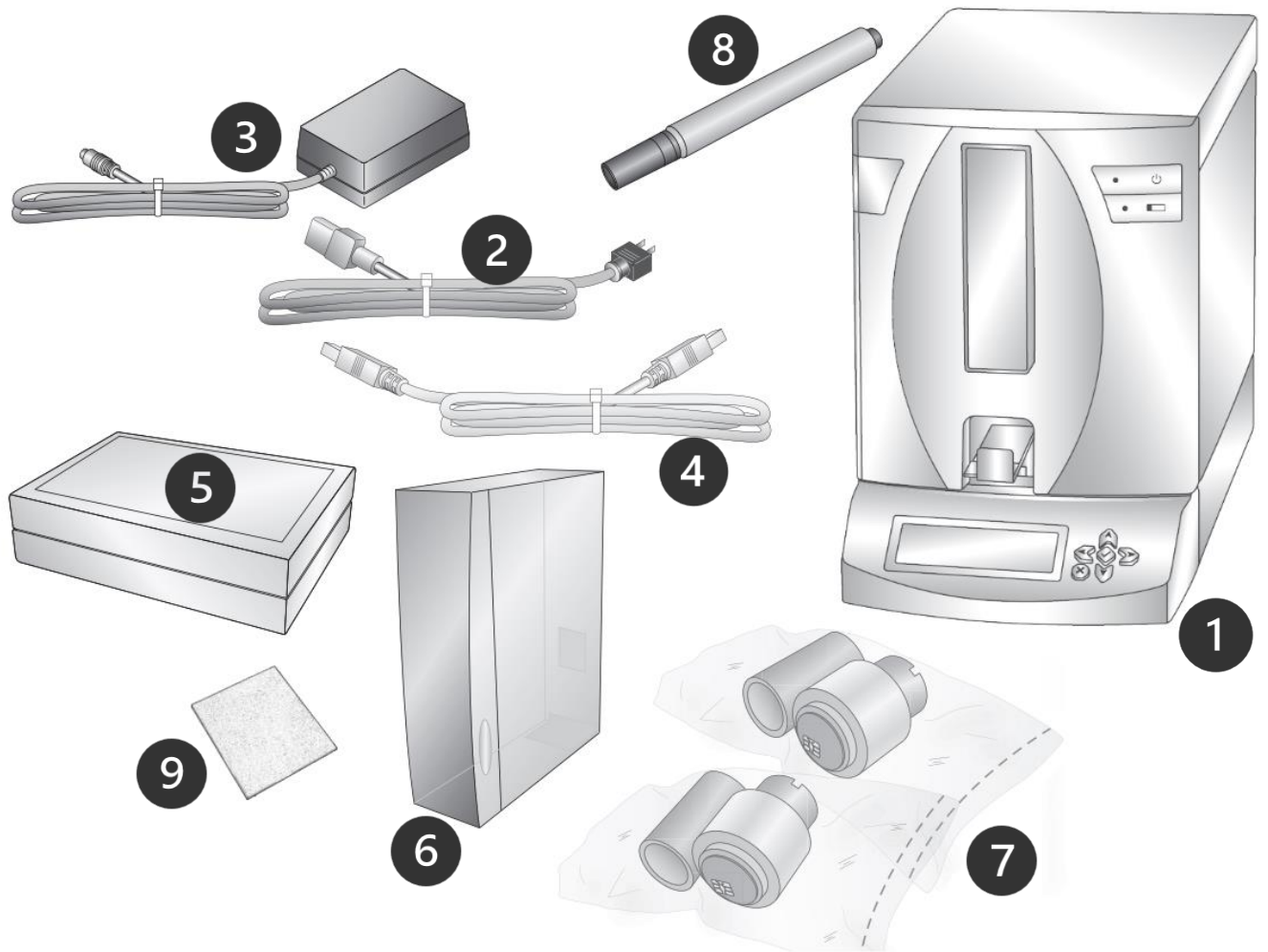

1C. Identifying the Parts

The following illustrations show the various parts of the printer. These parts will be referred to throughout this manual so return here if you ever encounter a term that is unfamiliar to you.

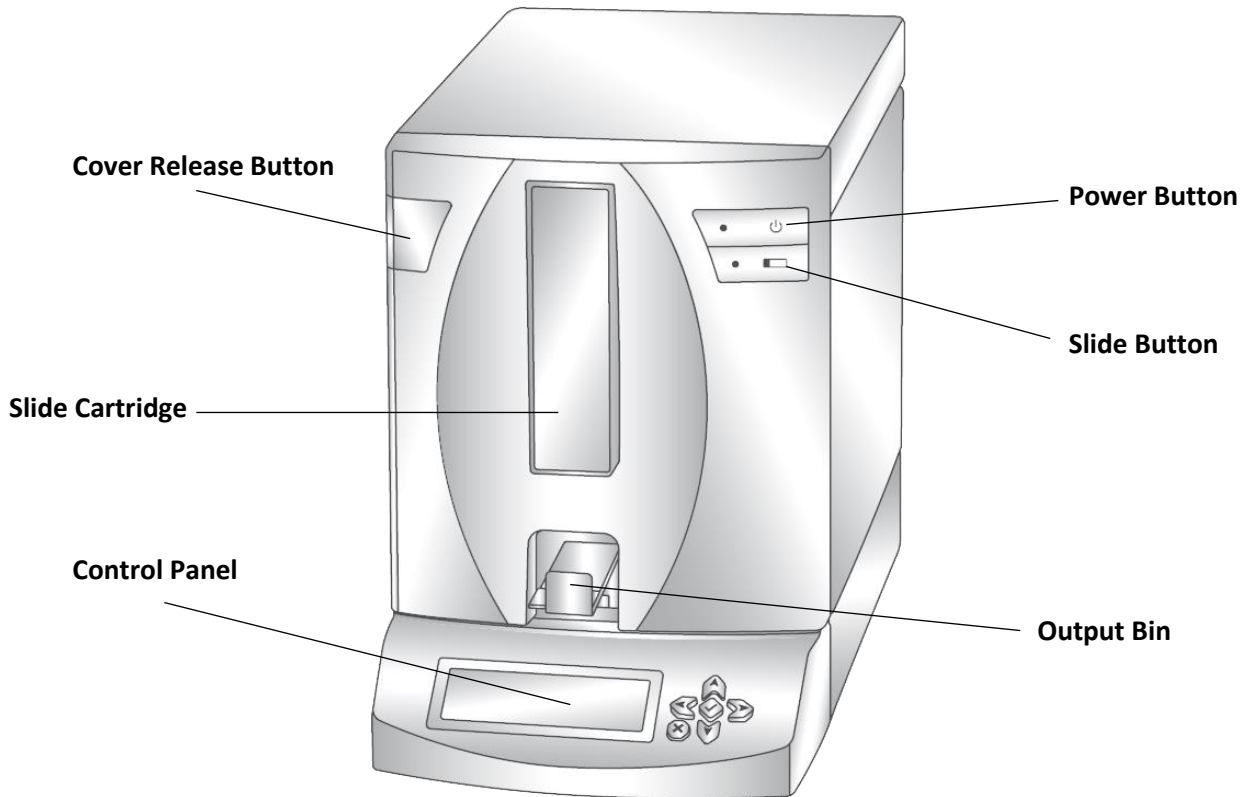

The **Cover Release Button** is a mechanical button that releases the spring-loaded mechanism on the cover.

The **Power Button** turns off the printer when the cover is closed. When the cover is open, press and hold the power button to reverse the slide rollers motors.

The **Slide Button** will advance any slide stuck in printer to the Slide Bin. When the cover is open, press and hold the slide button to advance the slide roller motors.

The **Output Bin** will hold 15 Slides when it is fully ejected. Pull the Slide Bin forward to fully eject it. A sensor will trip if more than 15 standard 1mm slides are in the bin.

The **Control Panel** can be used to view printer status, Error messages and Network information.

The **Slide Cartridge** holds 100 blank Slides.

Rear View

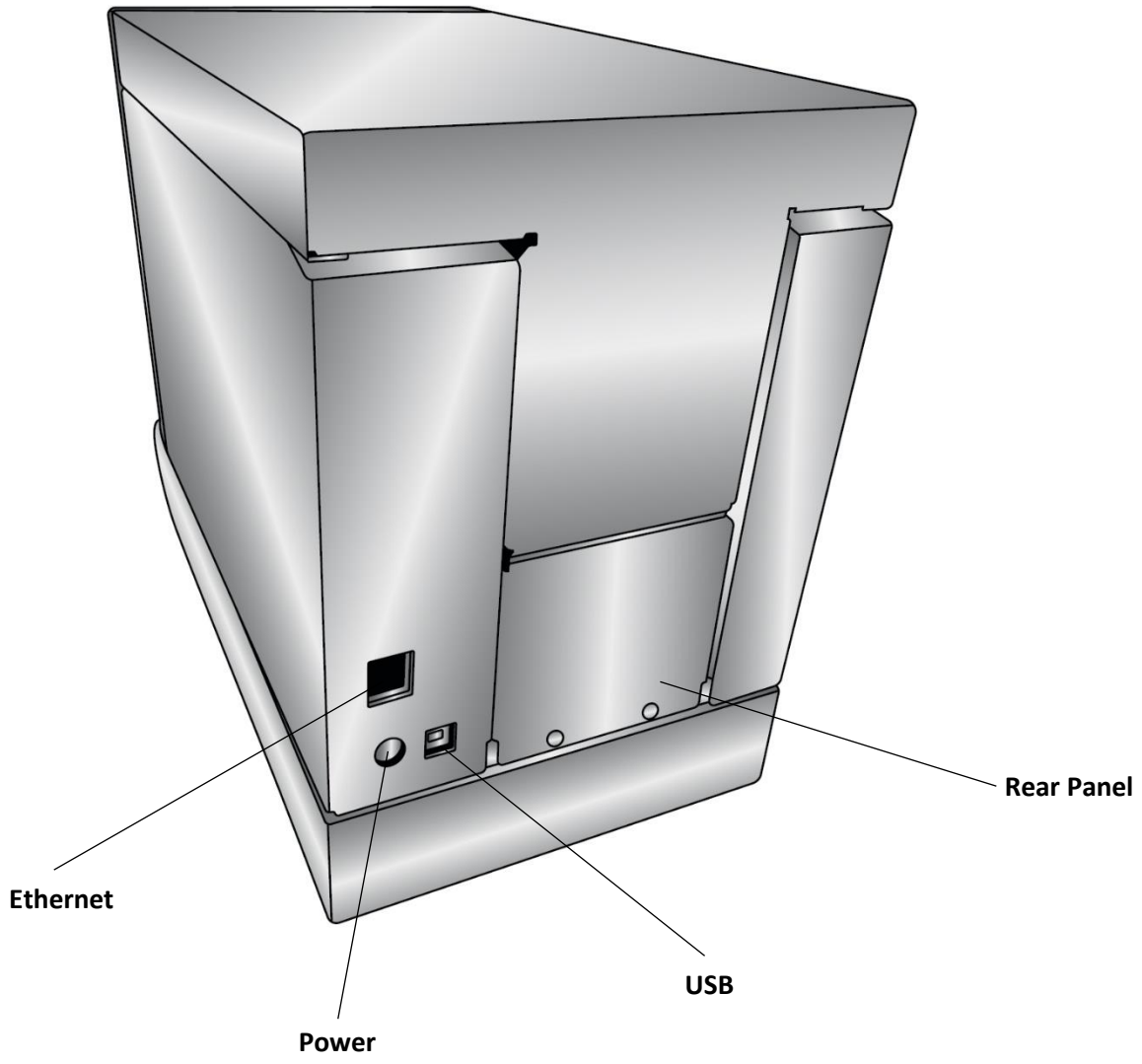

1D. Slide Specifications

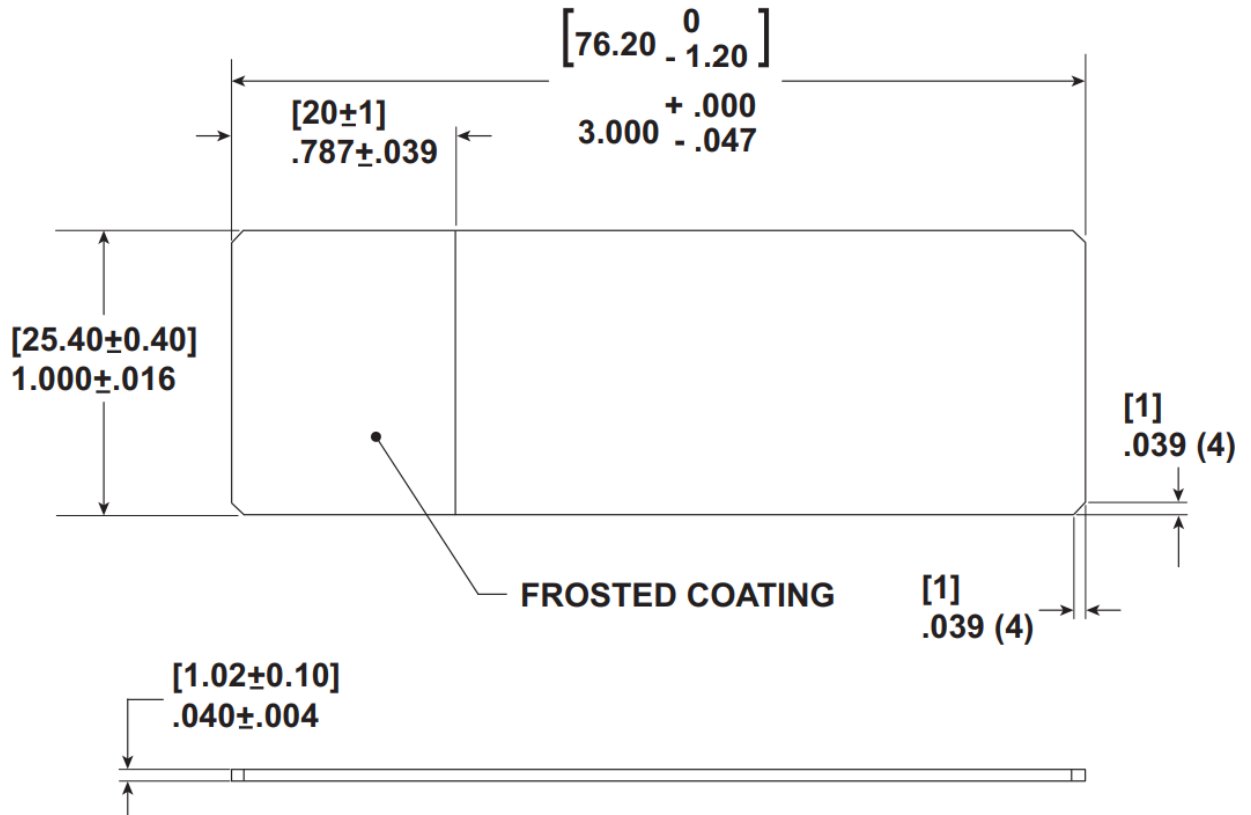

Slides should be 1.00" x 3.00" x .040" and have ground edges. Primera recommends using clipped corners (1mm x 1mm), but 90° corner slides can also be used. The slides must have a coated frosting, and it should cover 20mm of the length of the slide. The coating must be of uniform thickness across the entire width of the slide. The Signature EVO Slide Printer uses thermal transfer print technology. This print technology requires stricter standards on the surface finish and cleanliness of the slide's frosted coating compared to slides that are used with ink jet technology printers. The coating must be smooth and free of any clumps or dust embedded in the coating or print defects will occur.

1E. Connect Power

Attach the power cord to the Power brick. Plug the power cord into a grounded outlet and the 5mm barrel connector to the back of the printer. The power converter is a universal 100v-240v input and a 12v output.



1F. Load a Ribbon

The Signature Slide Printer uses either a Black ribbon (5000 prints) or a CMYK Color ribbons (1000 prints). You must use Primera ribbons to print with the Signature Slide Printer.

1. Remove a Color or Black Ribbon from its packaging. Detach the take up ribbon from the supply ribbon by gently pulling them apart.

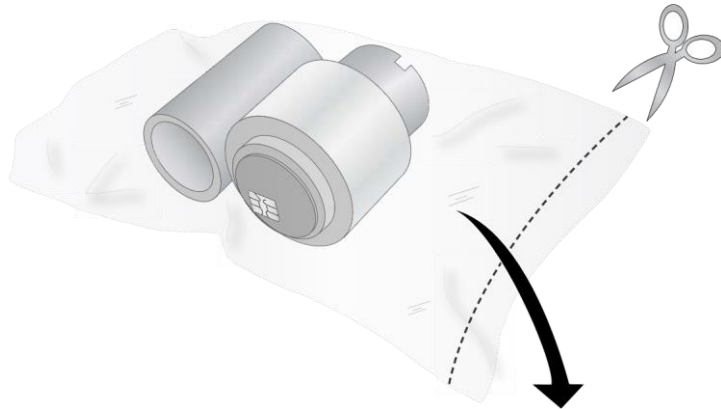

2. Open the top cover by pressing the release button on the left side of the printer.

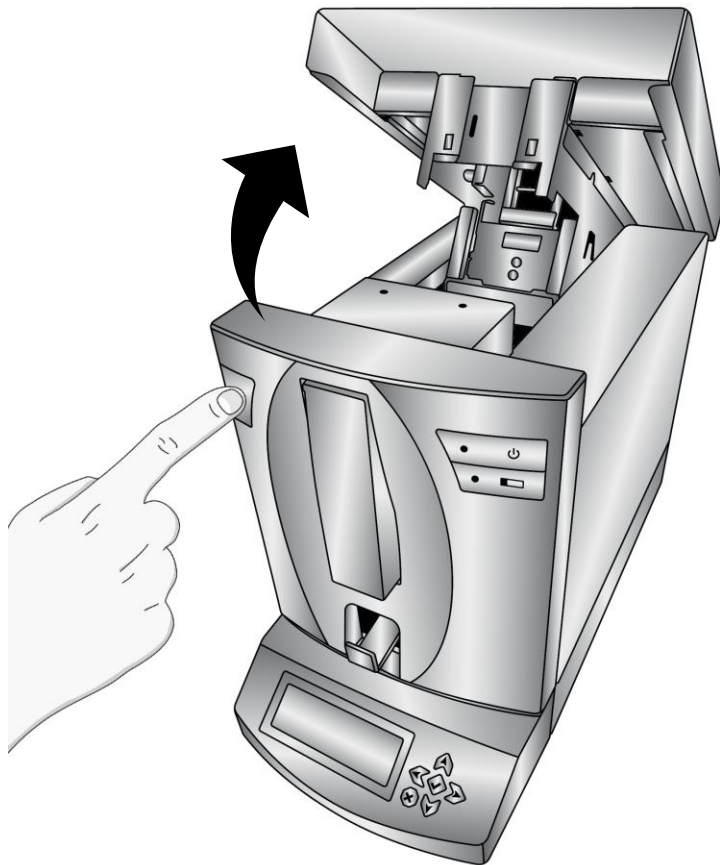

3. Remove the ribbon from its shrink-wrapped packaging.

Hold the take up (back) ribbon core with your left hand.

Hold the supply (front) ribbon with your right hand. Install the take up ribbon by depressing the spring-loaded hub inside the printer. Snap the take up ribbon core into place.

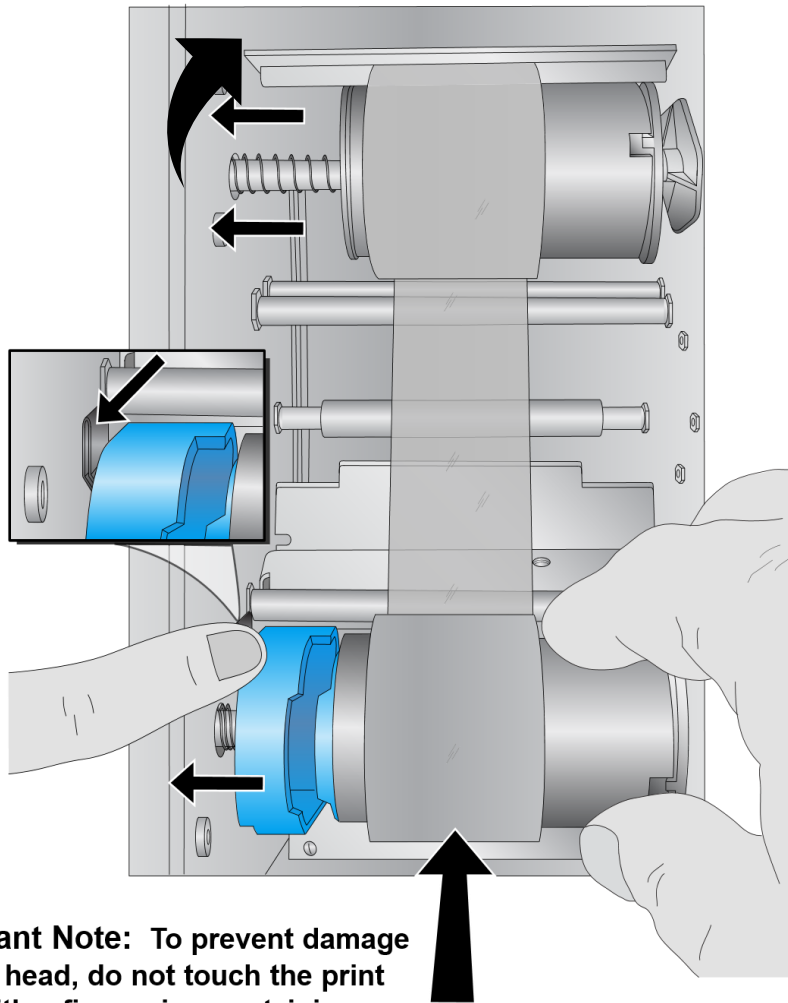

Important Note: To prevent damage to print head, do not touch the print head with a finger ring containing diamond or metal.

4. Push the blue spring-loaded hub by depressing the tab with your left pointer finger. Insert the supply ribbon straight down. Match the blue shape on the ribbon to the corresponding depression on the hub. (You may need to rotate the blue shape on the ribbon.)

5. Rotate the hubs until the tabs on the right side hubs match the notches on the ribbon. Manually turn the take up core until the ribbon is taut.

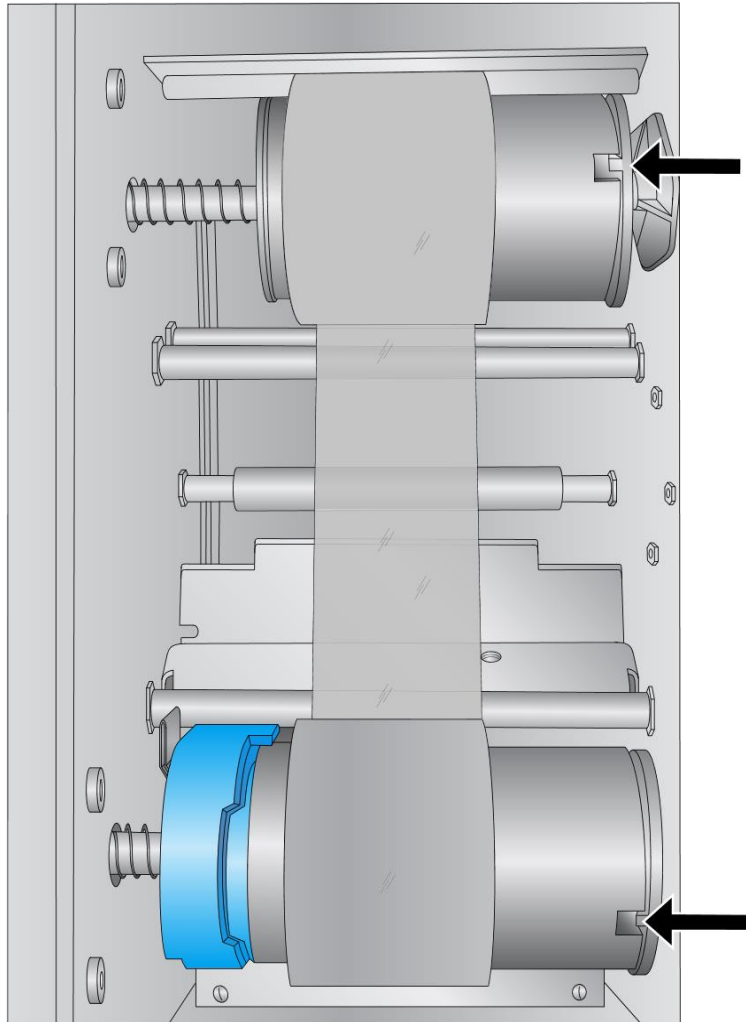

1G. Load a Slide Cartridge

1. Remove the empty blue slide cartridge by pulling up and out.

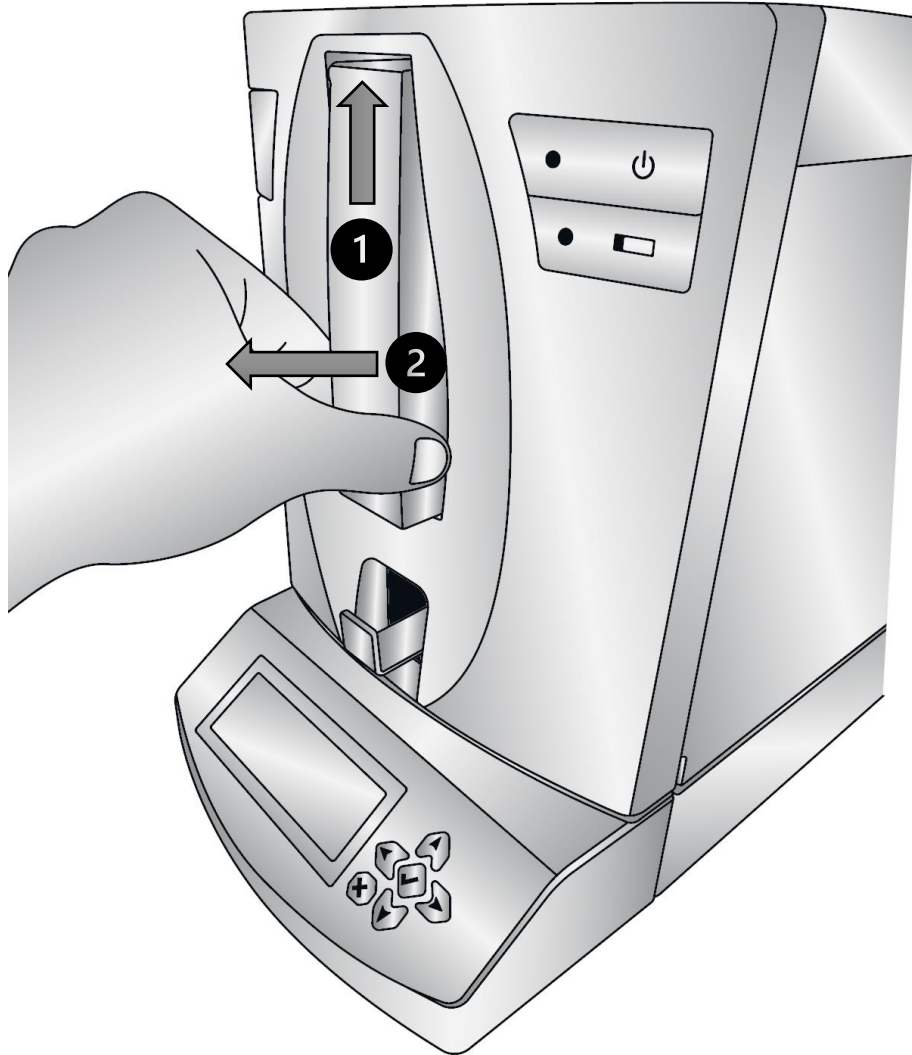

2. Open the blue slide cartridge.

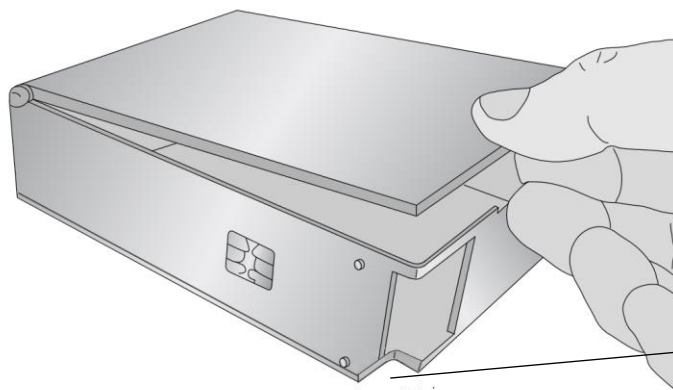

Note: The EVO requires a new slide cartridge with a cut out section for proper air puffer operation. The old slide cartridges from the original slide printer will NOT work.

3. Locate the 100 pack slide box.

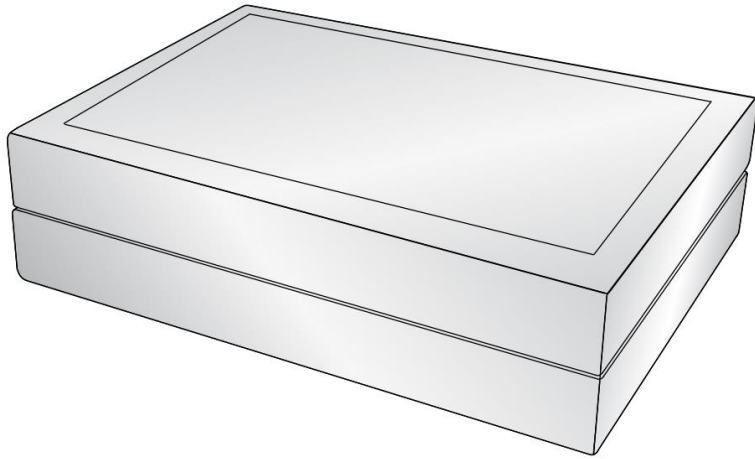

4. Place the slides next to the blue side cartridge so that the printable surface is on the TOP of the slide with the orientation shown below. **Note:** To achieve the proper orientation, it may be necessary to replace the box top, flip the box over and remove the other side of the box.

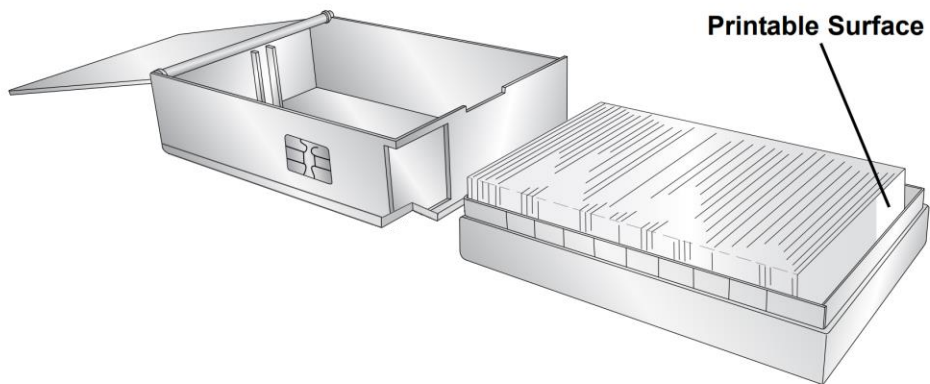

5. Carefully tip the slide box into the slide cartridge. The bottom slide in the box should rest on the edge of the slide cartridge. Note the location of the printable surface.

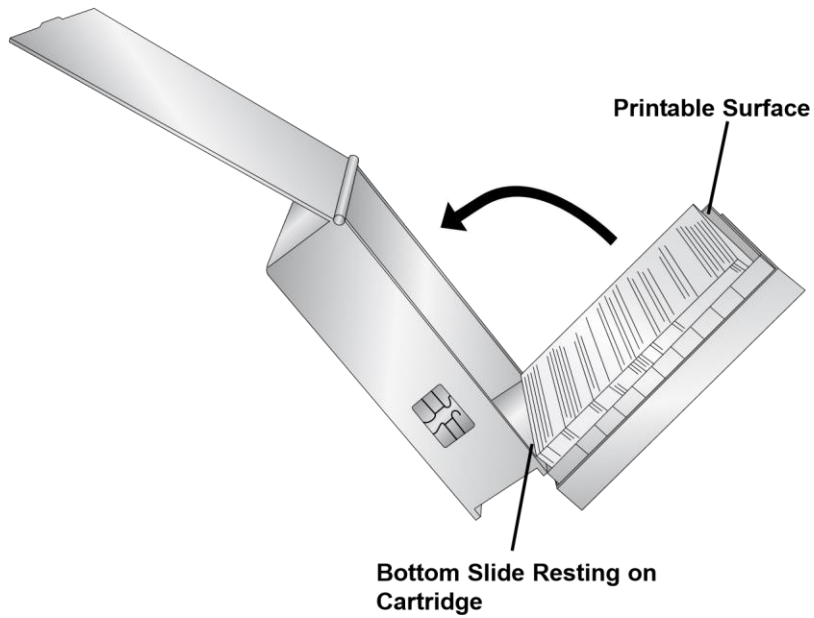

6. Once the slides are in place, straighten any that did not properly fall in the cartridge and ensure the printable surface is facing up and near the front of the cartridge as it is placed in the printer.

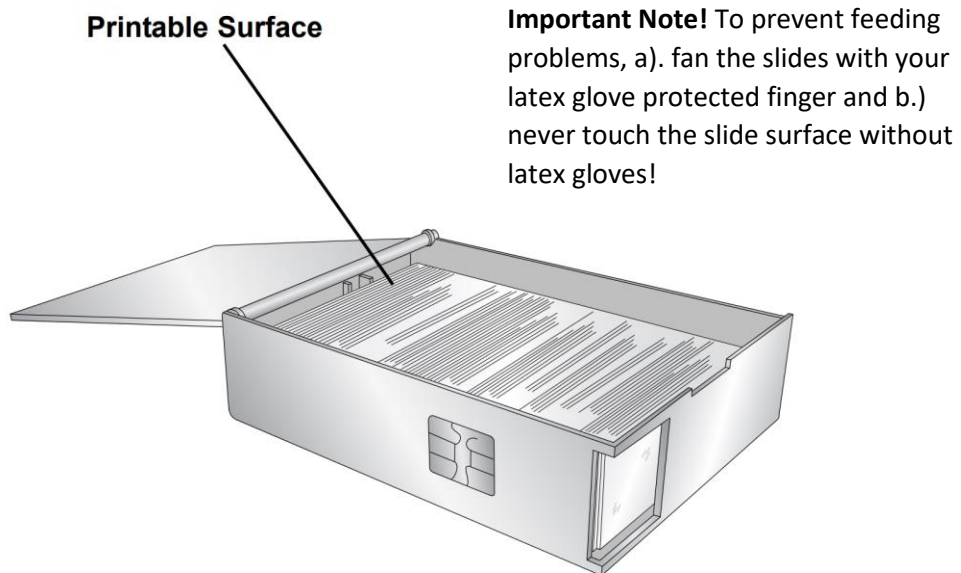

7. Close the lid and insert the cartridge into the printer. Push near the bottom of the cartridge until you hear a click.

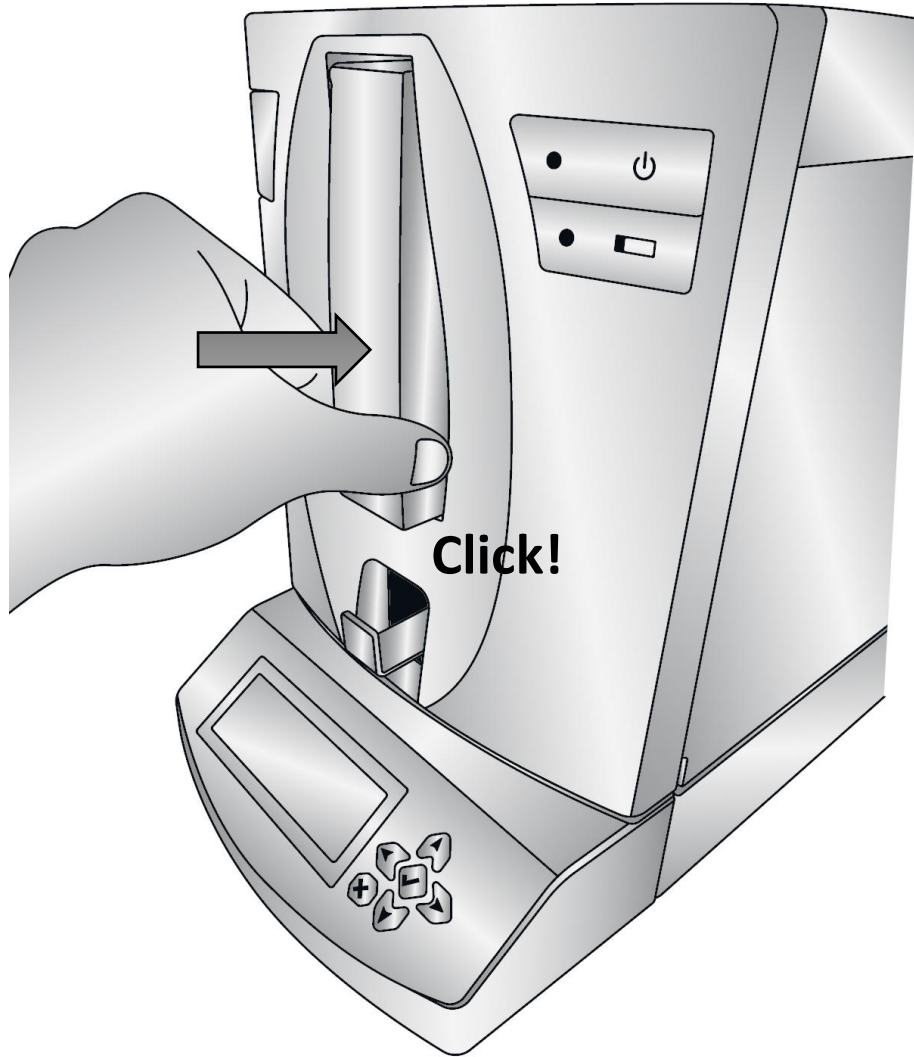

Important Note! The blue LED light will turn on when both the slide cartridge and ribbon are correctly installed.

Section 2: Printing Slides

The included PTLab SE software can be used to print to the Signature EVO Slide Printer. The PTLab software has its own manual. Please refer to it for detailed capabilities.

2A. Printing from other Programs

Printing to the Slide Printer from other software (besides PTLab SE) can be accomplished by using the standard Windows driver. The document requirements are listed below:

- Default Page = .87" (22mm) W x .67" (17mm) H
- Colors = Cyan, Magenta, Yellow, Red, Blue/Purple, Green, Black
- All colors must be 100% saturated

To print, simply go the applications print function. Choose the "Slide Printer" as the printer. Click OK to print.

2B. Printer Driver Settings

Click the Start button, search for "Printers". Select Printers and Scanners. Select Slide Printer. Choose Manage. Select Printing preferences.

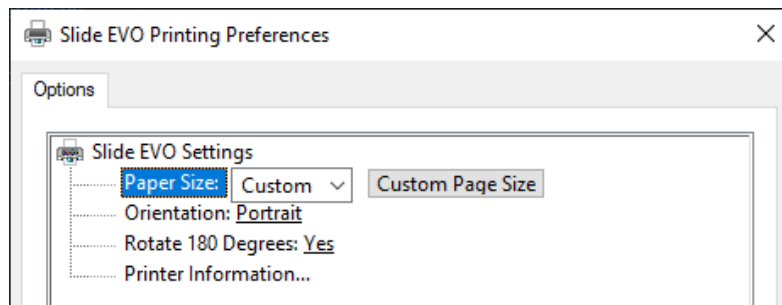

Paper Size: Default paper size is set to the maximum. Edit these settings if you are printing to slides with a smaller printable area.

Orientation: Change the orientation to Portrait or Landscape.

Rotate 180 Degrees: Flips the image up-side down . Default setting is Yes.

Printer Information... Click here to display, printer driver versions, firmware versions, total prints, current status, remaining slides, remaining prints and offset values.

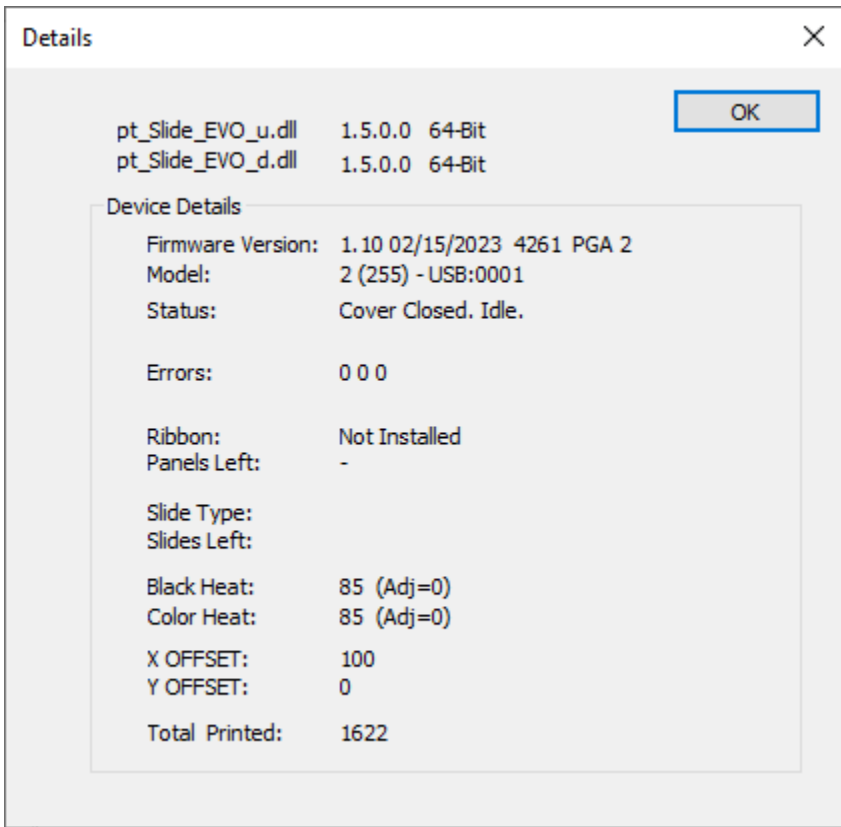

Section 3: Maintenance and Troubleshooting

3A. Control Panel Status Messages, Indicator Lights and Error Codes

The Control Panel will display the number of prints and slides remaining. When there is an error, it will display the error instead of the slide/ribbon count. Occasionally you may need to press the arrows to scroll through error messages or press the check button to dismiss an error. You can also see some network information on the control panel.

Control Panel

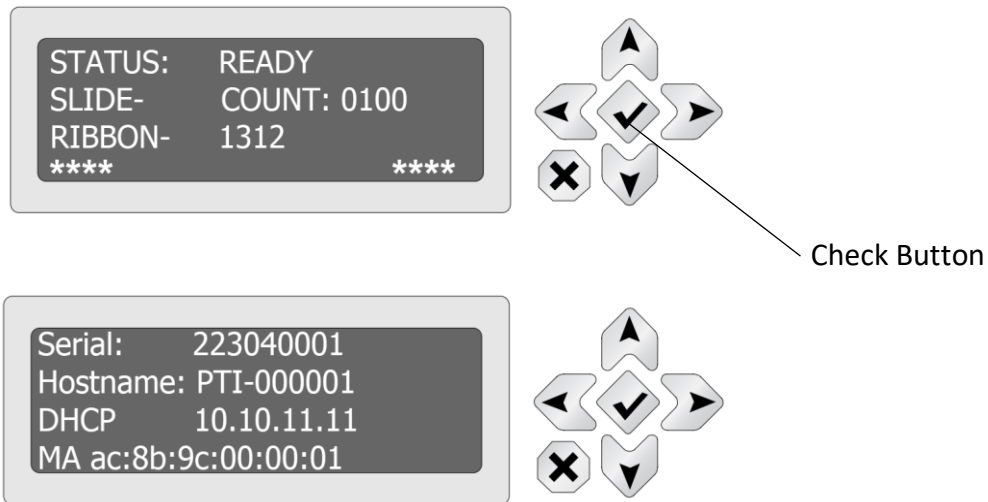

Indicator Lights

Power light on Steady - Slide Cartridge light ON	Ready to receive Print.
Power light on Steady - Slide Cartridge light OFF	No ribbon installed and/ or No Slide Cartridge Installed.
Flashing Slide Cartridge light and slide button light	An error is present. Refer to error code or error message displayed in the printer information dialog in the printer driver preferences area. See the error code list below. (PTLab will display these errors in the software)

Error Codes (Found in Printer Driver Details)

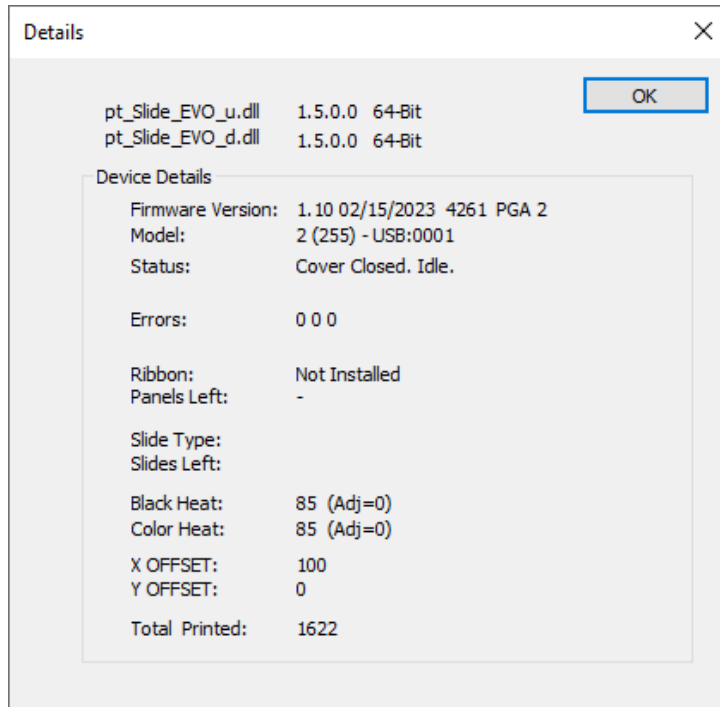

Slide Cartridge Invalid	80 0
Ribbon PWM	40 0
Head Load	20 0
Input Empty	10 0
Input Jam	08 0
Ribbon Advance Error	04 0
Ribbon Invalid	02 0
Lifter Not Functioning	01 0
Ribbon Out	00 01
Ribbon Break	00 02
Output Full	00 08
Slide Connection Error	00 10
Ribbon Connection Error	00 20
Ribbon Jam Error	00 40

3B. Cleaning the Print Head

A print head cleaning pen is included with the printer. Clean the print head after every ribbon change or if you notice quality problems such as vertical line through the entire print.

1. Unplug Power.
2. Open the printer cover.

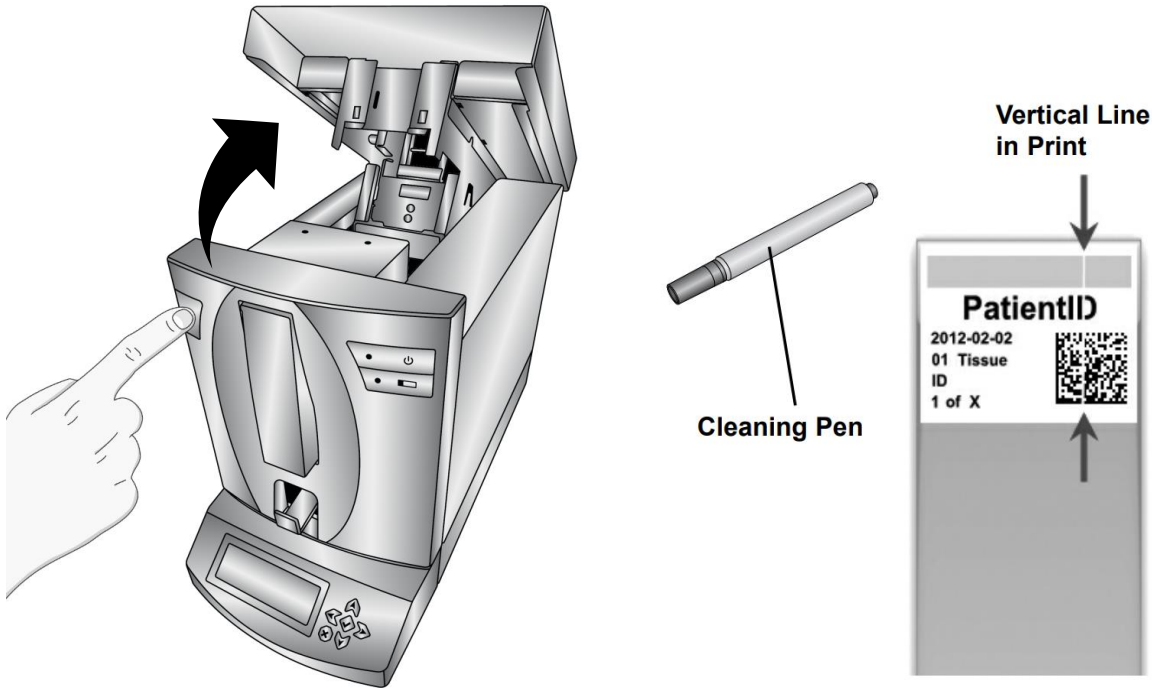

3. Locate the Print head mounted to the underside of the cover.

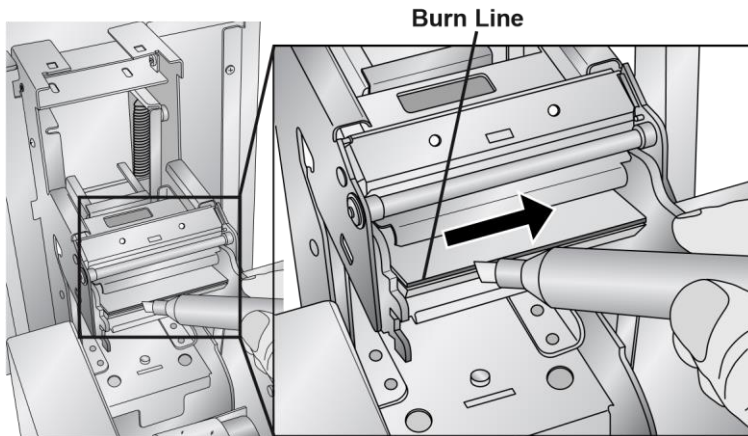

Important Note: To prevent damage to print head, do not touch the burn line with a finger ring containing diamond or metal.

4. Clean the print head using the print head pen. Swipe the tip across the burn line 1 or 2 times. If you notice the tip getting dirty, clean it by wiping it across a clean paper surface.

- 5. If the cleaning pen does not resolve the issue, the pink Polishing Paper (895703) should be used. Rub the paper over the print head burn line a few times to help remove any built-up debris.

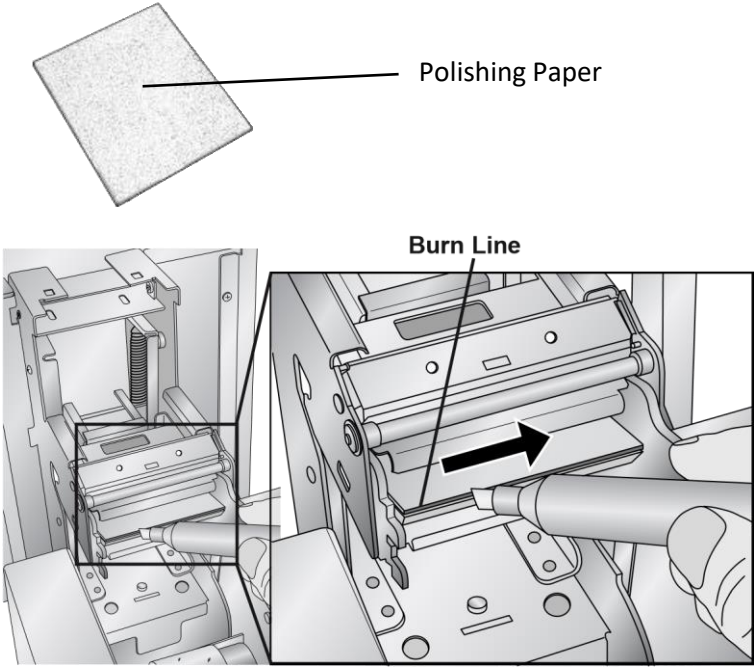

- 6. If these steps do not resolve the issue, it may be time to replace the print head.

3C. Replacing the Print Head

If cleaning the print head (Section 3B) does not resolve a quality problem such as a vertical line through the entire print, it may be time to replace the print head. Print heads are designed to last tens of thousands of prints. However, it is possible a premature failure could occur if high heat settings were continuously used, it is used in a particularly hot environment or if slides not recommended for the printer are used.

Print Head Part Number : 78250

1. Unplug Power.
2. Open the printer cover.
3. Locate the Print head mounted to the underside of the cover.
4. Push back , then down and then flip it 180 degrees to reveal the cable connector. Watch the pin on the side of the print head mechanism to guide the print head out of the metal housing.

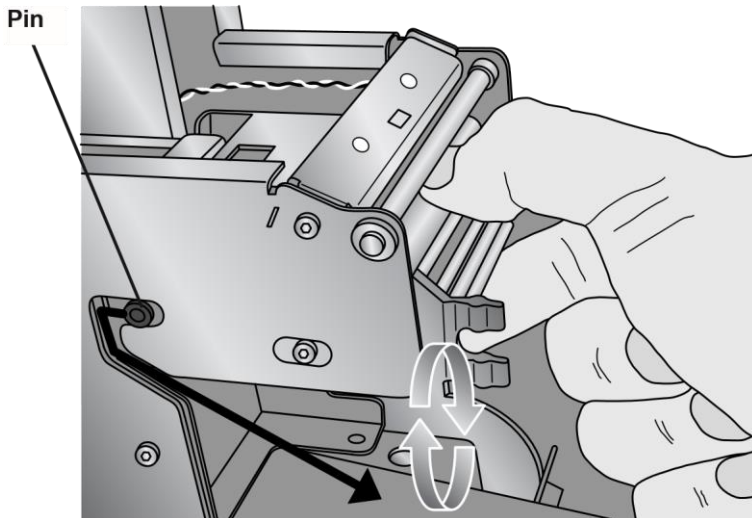

5. Disconnect the cable from the connector. Pull on the cables to remove the connector.

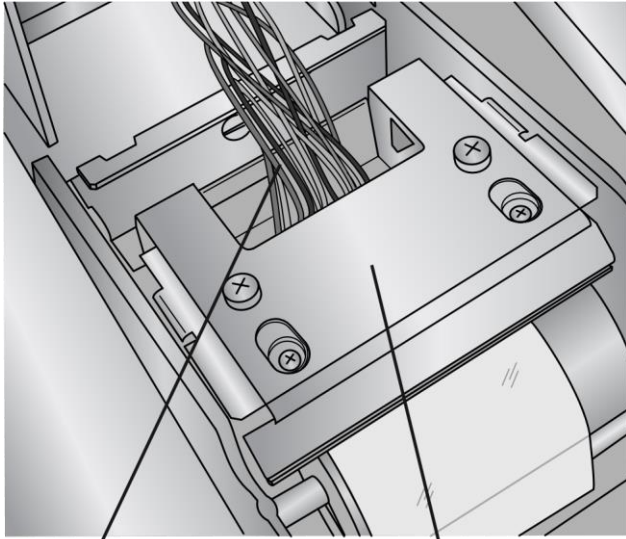

Disconnect this Cable Print Head Flipped 180 Degrees

6. Connect the new print head.
7. Rotate the printhead 180 degrees and push it back into the metal housing.
8. **IMPORTANT!** Find the Resistance value printed on the printhead.
Example: R= 3180

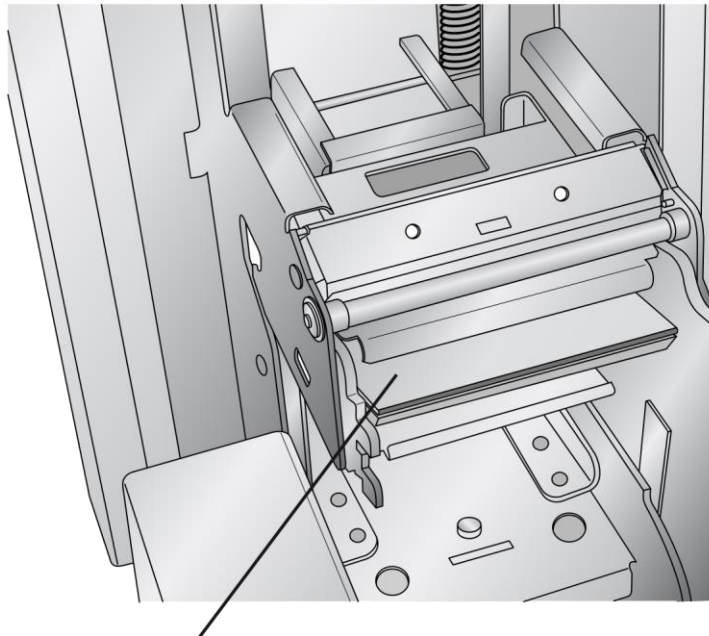





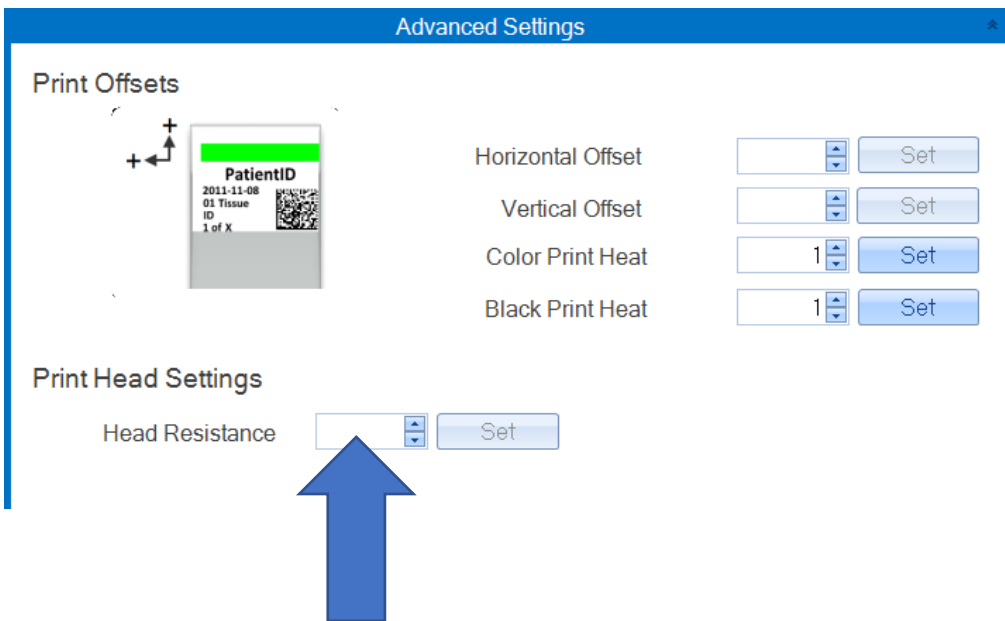
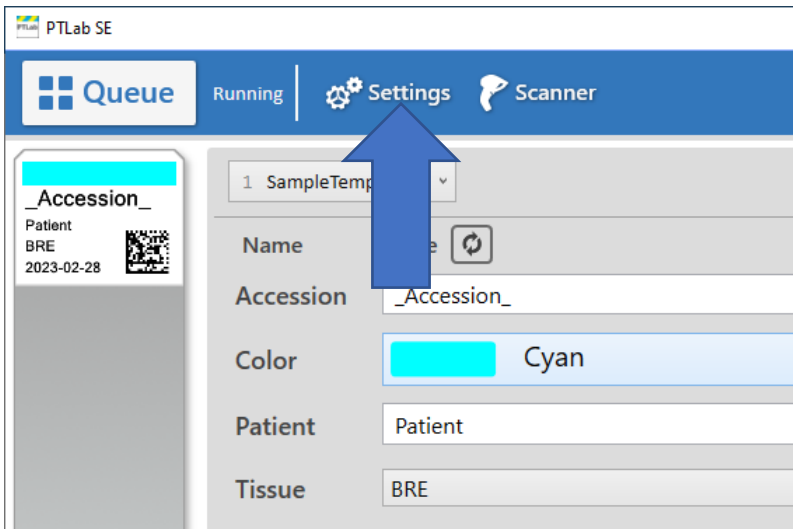

Resistance Value Printed Here

Before printing, enter this value in the advanced settings area of the PTLab software.
Click the settings icon in the upper left corner of PTLab. Click the Advanced Settings Tab.
Enter the Head Resistance. Click Set.



3D. Troubleshooting Print Quality

Print Quality problems are usually caused by debris or flaws on the printable surface of the slide. Use the chart below to diagnose quality problems.

	<p>Vertical Line. A line vertically through the entire print is caused by dust or debris on the print head burn line or blown pixel on the print head. See Section 3B for cleaning instructions and 3C for print head replacement instructions.</p>
	<p>Horizontal Line. A horizontal line through print is caused by a small bump on the slide. This causes the entire print head to lift at this point so the effect of the bump is extended to the left and right of the bump. Low quality or defective slides may be the cause.</p>
	<p>Group of Spots. This may be caused by dust particles on the slide. Keep the slide clean. Store them in the blue slide cartridge at all times. Avoid handling the slides. Do not remove them from their shrink wrapping until you will be inserting the slides into the blue cartridge.</p>
	<p>Light Printing. Light printing is caused by insufficient heat or slides that are not thermal printable (inkjet). You may be able to improve quality by increasing the heat setting in the Printer Preferences or the PTLab software. Different manufacturers of slides may require more or less heat. The minimum heat settings possible that result in a good print should be used. (Section 2B)</p>
	<p>Random Missing Area (Print Surface Intact). This is caused by a rough printable surface. Low quality slides, defective slides or slides that are not thermal printable (inkjet) may be the cause.</p>
	<p>Random Missing Area (Printable Surface Missing). If the printable surface is missing or scratched off, the printer cannot print in these areas. Low quality slides, defective slides or mishandling of slides may be the cause of this problem.</p>
	<p>Rounding at the leading edge. Rounding at the leading edge of any new color on a slide is typically caused by low quality slides or slides that are not thermal printable (inkjet).</p>

3E Changing the Spring Force (Printing Pressure)

For rougher surface slides such as those manufactured for handwriting or inkjet printing, the higher print head pressure may be necessary to achieve optimal print quality. If you have smooth sides, the higher force might cause ribbon breaks or poor quality. To adjust spring force, you can push the lever inside the top cover.

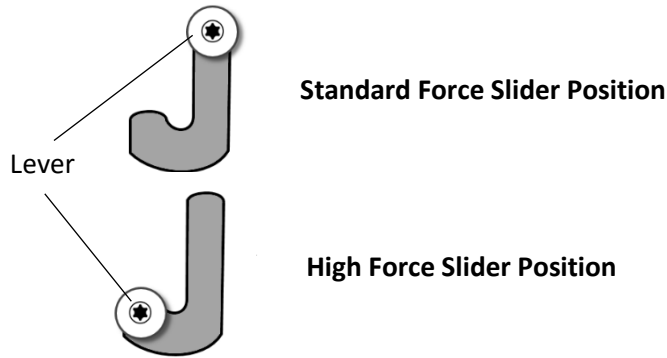

To access the slider, open the top cover. The lever is located inside the top portion of the cover just above the print head.

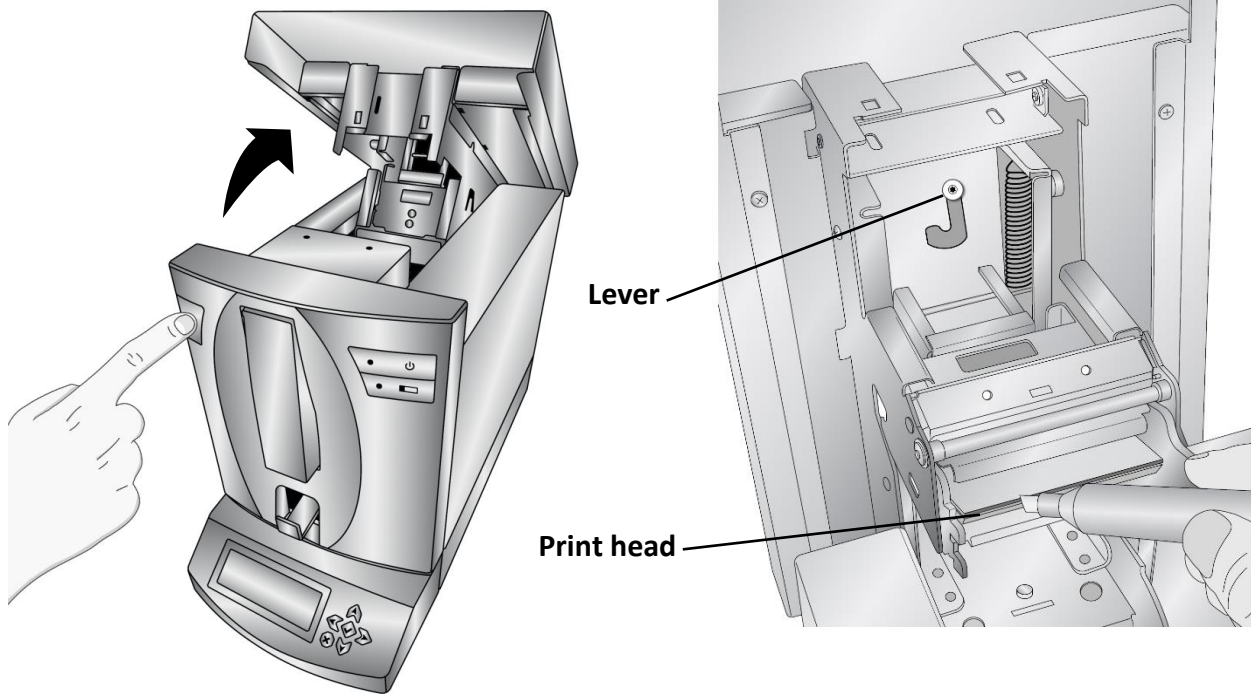

Push the lever down and to the left to put it in high force mode. Push down and to the right to put it in standard force mode. The lever is under spring loaded pressure so it should be especially hard to push down the side of "J" to the high force position.

3F. Repairing/Preventing Ribbon Breaks

Ribbon breaks can occur if the head setting is too high. To repair a ribbon break follow this procedure:

1. Open the cover.
2. Locate the supply roll ribbon. Place it on the top of the print as shown below. Attach a piece of tape.

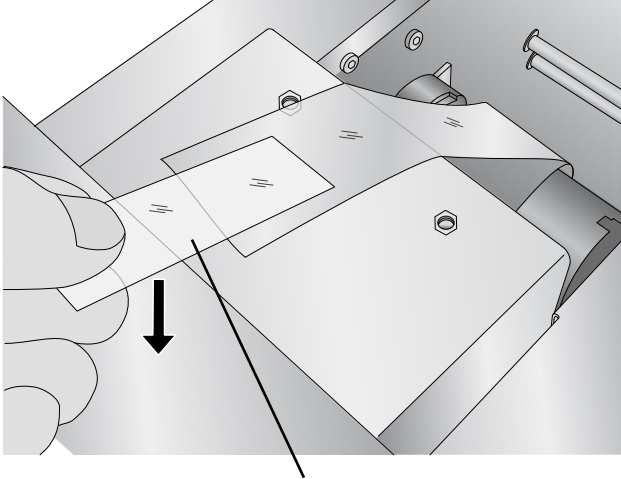

Tape Sticky Side Down

3. Feed the supply side of the ribbon under the take up roll. Tape the supply ribbon to the take-up roll.

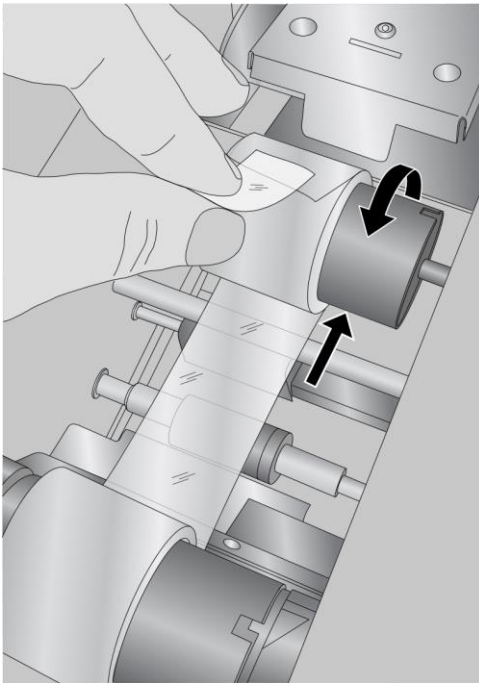

4. Manually turn the take-up roll several complete rotations to prevent the tape from coming loose.
5. Close the Cover.

3G. Retrieving a Broken Slide

If a slide is broken or stuck in the system there are two access panels that can be used to retrieve the slide. If a slide is found inside the printer, use the Power and Slide buttons to move the internal slide rollers forward and back to advance the slide to a point where it can be removed. Follow this procedure:

1. Open the top cover.
2. Remove the Ribbon.
3. Remove the slide cartridge.

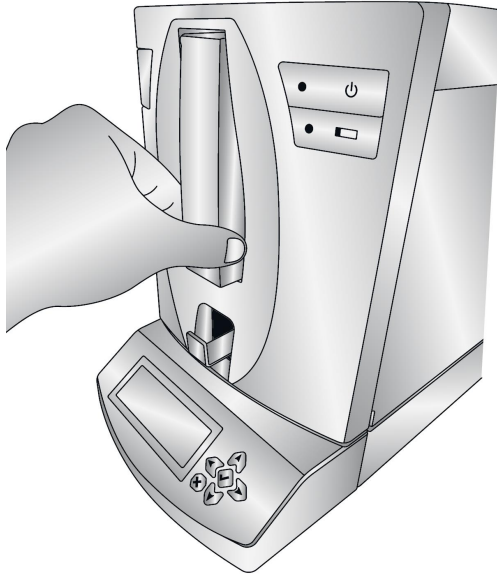

4. In the slide cartridge compartment check near the bottom roller for a slide.
5. Check under the ribbon. Use the Power and Slide buttons to move the slide to a position where you can remove it. **Tip! Once the slide is on the rubber belts near the back, you can close the cover and press the slide button to advance the side down the slide chute.**
6. If the slide is near the back and you are unable to retrieve it using the buttons you can remove the back cover panel.

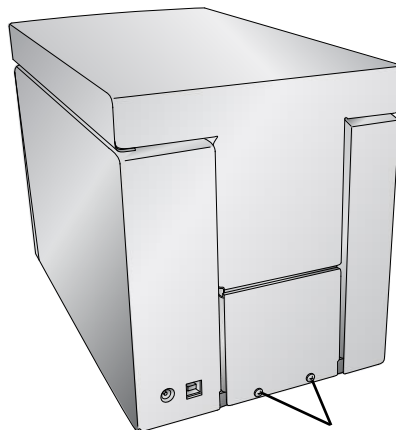

Screws for Access Panel

7. Finally, if the slide is broken you can remove it using the bottom catch bin. Pick up the slide printer and rotate it in multiple directions until all of the pieces are in the bin. Now pull out the bin and empty it into the trash.



3H. Cartridge or Ribbon Recognition Problems

If your cartridge or ribbon is installed but the blue LED light behind the cartridge does not turn on or the software says no cartridge or ribbon is installed, you may need to clean the copper chip on the ribbon or slide cartridge with an alcohol wipe.

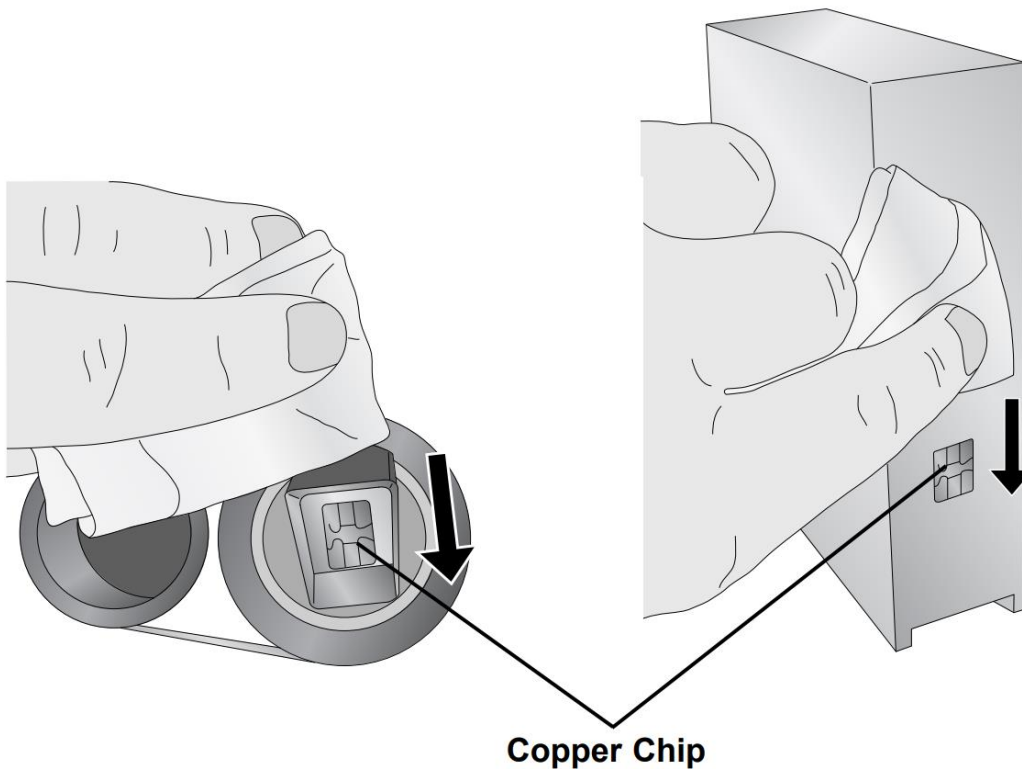

3I. Adjusting the Slide Separating System

The slide separating system supplies an air burst between the bottom two slides in order to separate the slides as they feed out of the slide cartridge. The slide separating system uses a pump and compressed air. You may occasionally hear sounds of the compressor and the air being released.

There are three modes available in the PTLab software.

1. **Engage when needed.** This is the default setting. In this mode the air burst is only used when the slide is not pulled from the cartridge on the first attempt. The system will try again while using the air burst to assist the slide separation.
2. **Engage every slide.** In this mode the air burst is used on every attempt to feed a slide. This mode takes more time and is louder than the engage as needed mode.
3. **Disabled.** In this mode the air burst is disabled.

To access this setting, open PTLab and click on the settings icon in the upper left – Click the Advanced Menu.

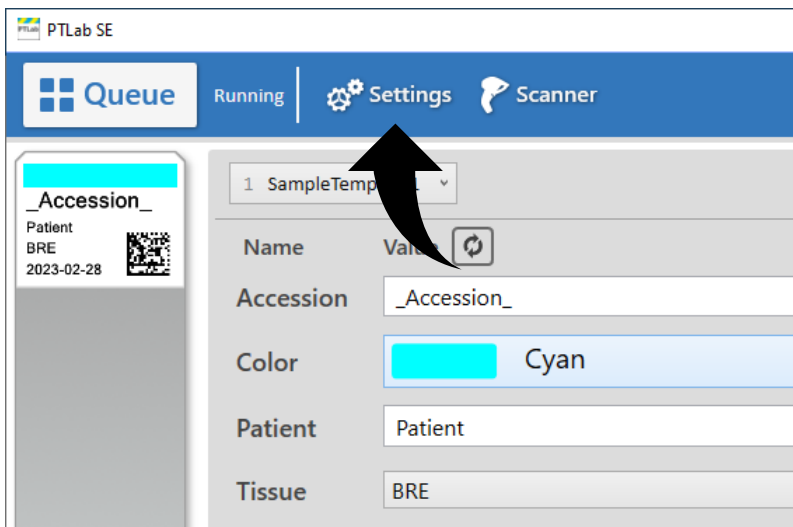

3J. Technical Support.

If you have difficulties operating your Printer, contact technical support using one of the methods listed below.

Primera Knowledge Base	www.primera.com/kb
Email Support	www.primera.com/customer-support
Phone Support	763-475-6979 (Mon - Fri 8 a.m. - 5 p.m. CST)
Chat	www.primera.com – see chat icon in lower right corner (Mon - Fri 8 a.m. - 5 p.m. CST)

Section 4. Technical Specifications

Printing technology:	Thermal transfer
Print speed:	Up to 10 slides/minute (monochrome) Up to 7 slides/minute (solid colors)
Print resolution:	300 dpi
Ink type:	Resin thermal transfer
Ribbon types:	CMYK: 1000 prints Black: 5000 prints
Printable colors:	8 solid colors
Slide types:	3" x 1" standard or positive charged, frosted end
Slide capacity:	100 slides/cassette
Output tray capacity:	15 slides
Construction:	Steel frame with powder-coated steel and plastic covers
Cabinet color:	Medical white
Data interface:	USB 2.0 and Ethernet
Printer drivers:	Windows™ 8 / 10 / 11
Height:	10.93" (277.7mm)
Width:	7.08" (179.8mm)
Depth:	14.73" (374.1mm)
Weight:	23 lbs. (10.43 kg)
Power requirements:	100-240VAC, 50/60 Hz, 60 watts
Warranty:	One year parts and labor

Section 5 Compliance

EMC: Class B

FCC:

NOTE: This equipment has been tested and found to comply with the limits for a Class B digital device, pursuant to part 15 of the FCC Rules. These limits are designed to provide reasonable protection against harmful interference when the equipment is operated in a commercial environment. This equipment generates, uses, and can radiate radio frequency energy and, if not installed and used in accordance with the instruction manual, may cause harmful interference to radio communications. Operation of this equipment in a residential area is likely to cause harmful interference, in which case the user will be required to correct the interference at his own expense.

Environmental Policy

The European Union (EU) has developed the WEEE (Waste Electrical and Electronic Equipment) Directive (WEEE Directive 2012/19/EU) to ensure that systems for collection, treatment, and recycling of electronic waste will be in place throughout the European Union.

Electrical and electronic equipment (EEE) contains materials, components, and substances that may be hazardous and present a risk to human health and the environment when waste and electronic equipment (WEEE) is not handled correctly.

Equipment marked with the below crossed-out wheeled bin is Electrical and electronic equipment (EEE).

The crossed-out wheeled bin symbol indicates that the product is EEE and must be collected separately, in accordance with the WEEE Directive 2012/19/EU.



Users of EEE must not discard WEEE together with household waste. Users must follow local recycling regulations to reduce adverse environmental impacts in connection with disposal of WEEE and to increase opportunities for reuse, recycling, and recovery of WEEE. As a user of this EEE, you have an important role in recycling this equipment and contributing to the protection of the environment and the conserving of natural resources.

When a product reached its end of life, contact us at environment@primera.com or +1-763-475-6676 to arrange its recycling. Primera will work with you to arrange for the recycling of the product.